

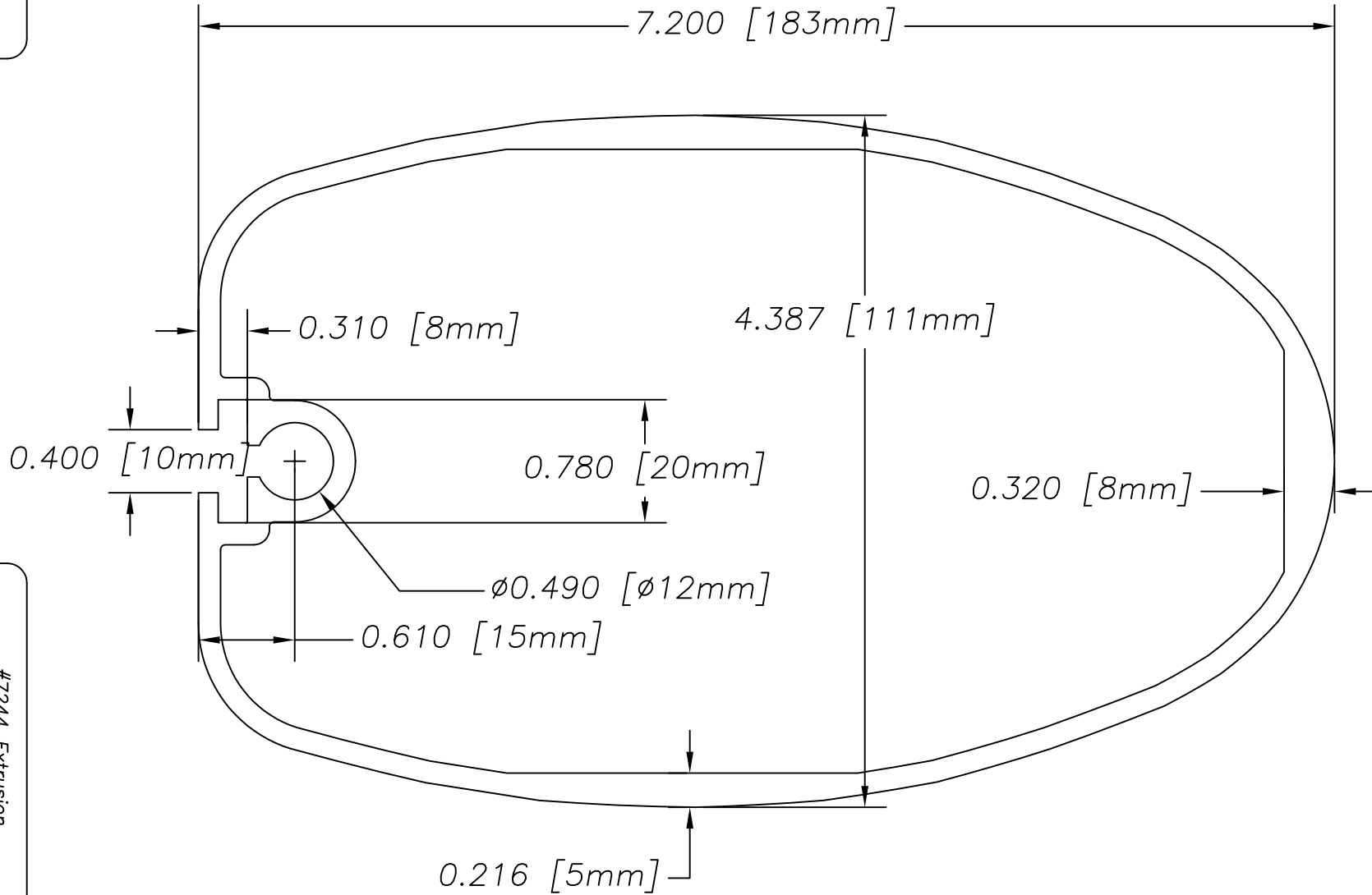

#7244 Extrusion

$$I_{xx} = 20.28 \text{ in}^4 \quad I_{yy} = 8.05 \text{ in}^4$$

$$\text{Area} = 3.35 \text{ in}^2 \quad Wt/Ft = 3.9 \text{ lb}$$



OFFSHORE SPARS USA
50200 E. RUSSELL SCHMIDT BLVD
CHESTERFIELD TWP, MI 48061 USA
TEL: 986-598-4700
FAX: 986-598-4705

OFFSHORE SPARS EUROPE
OT OFFSHORE SPARS AB
68600 JAKOBSTAD FORTLAND
TEL: 359-6-7989900
FAX: 359-6-7989919

OFFSHORE SPARS WEST
617 38TH STREET
MANHATTAN BEACH, CA 90266 USA
TEL: 310-939-9853
FAX: 310-939-9853

#7244 Extrusion